

R75 STONE



Peso medio
Medium Weight



9010 BT



7035



1013



Cassonata totale a soffitto . Cassette awning ceiling application

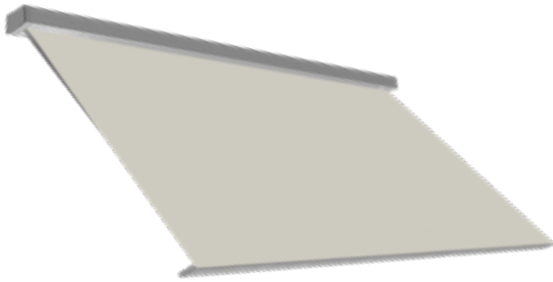

Tenda motorizzata con cassonetto a scomparsa totale per una perfetta protezione del telo e della struttura, dalla forma particolarmente compatta in modo tale da limitare l'ingombro in balconi dalle altezze contenute. Possibilità di attacco solo a soffitto. Carter laterali in alluminio a copertura di tutta la bulloneria. Regolazione micrometrica dell'inclinazione. Luci led integrate nel profilo cassonetto. Design depositato caratterizzato da effetto "pietra". Tenda indicata per balconi e forniture condominiali.

Total cassette motorized awning for a complete protection of the cloth and of the structure, with a particularly compact shape in order to limit the encumbrance in balconies with contained heights. Installation only at the ceiling. Aluminium side carter for covering all the exhibited screws. Regulation system for the inclination of the arms by micrometric screw. Led lights integrated into the cassette profile. Registered design characterised by the "stone" effect. Ideal awning for balconies and condominial supplies.



Attacco a soffitto . Ceiling application

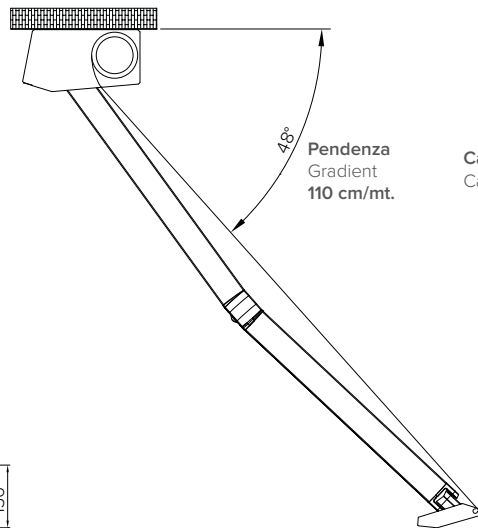
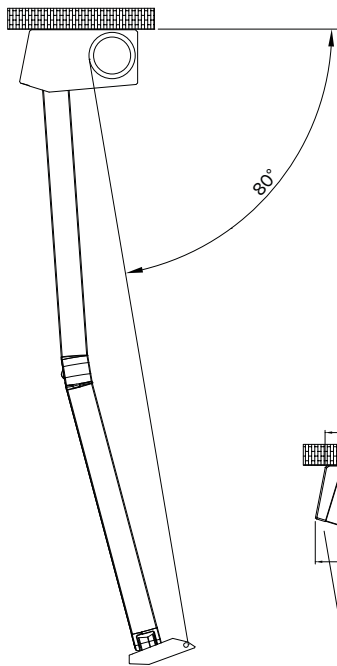

Carter centraline/alimentatori 095-910
Carter control unit/power supply

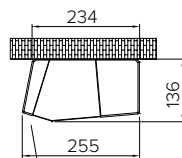
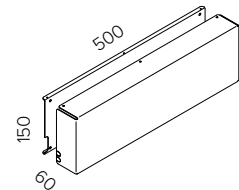

OPTIONAL
Luci LED integrate nel profilo cassonetto
Led lights integrated into the casing profile

Optional



+ 20%